

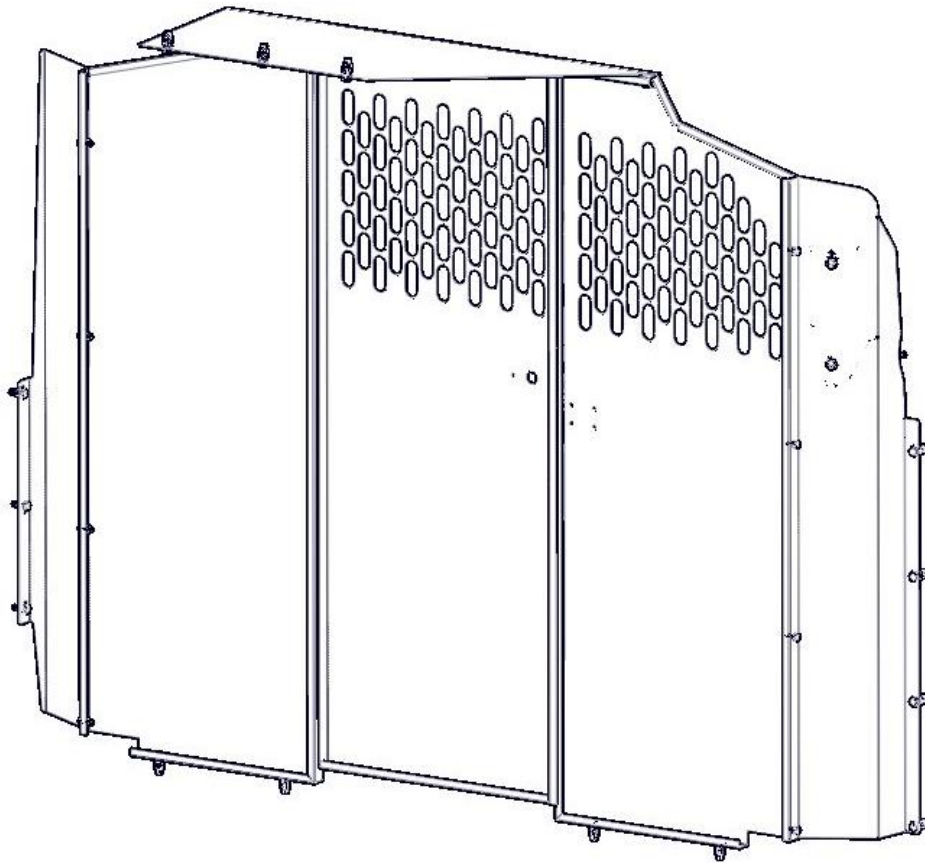

WE PUT EVERYTHING WITHIN REACH.

Installation Guide

406TL



Kargo Master
Rancho Cordova, CA 95742
800-343-7486
CustomerService@KargoMaster.com

DATE: _____

***PLEASE READ ALL INSTRUCTIONS AND WARNINGS PRIOR TO ASSEMBLING,
INSTALLING, AND USING THIS PRODUCT***

Warning



Always check for wires, fuel tanks and lines, brake lines and other important vehicle functionality items prior to drilling and installing all products.

Tools Needed

3/8" Wrench and Socket	7/16" Wrench and Socket
Drill	25/64" Bit
Phillips Driver	10mm Wrench and Socket
1/2" Wrench and Socket	9/16" Wrench and Socket

Table of Contents

Parts List 2

Hardware List 2-3

Step 1 Assemble Side Wings 4

Step 2 Assemble Top Wing 4

Step 3 Handle Replacement 5

Step 4 Plusnut Installation 6

Step 5 Bolt Partition into Place 7

Step 6 Driver Side Wing 8



Step 7 Handle to Handle 8

Step 8 Passenger wing 10

Step 9 Top wing 10



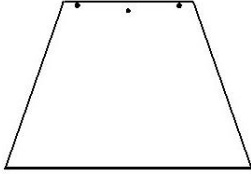

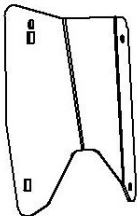
Before You Begin

- Read all instructions.
- Be sure to have 40640 (Standard Partion) assembled and ready to be installed.

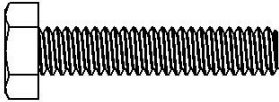
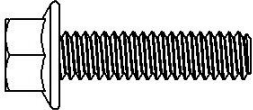
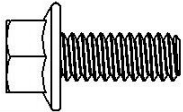
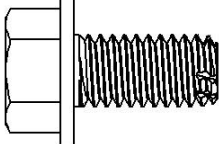
#	406TL PARTS	PART NUMBER	DESCRIPTION	QTY.
A		406TL-10-001-R1	Transit Low Roof-Top Panel	1
B		406TL-10-002-R1	Transit Low Roof-PS Wing	1
C		406TL-10-003-R1	Transit Low Roof-DS Wing	1
D		406TL-10-004	Transit Low Roof-Handle Mount	1

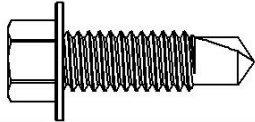
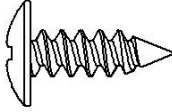
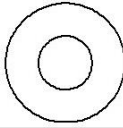
Hardware

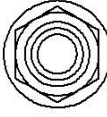
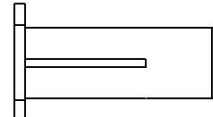
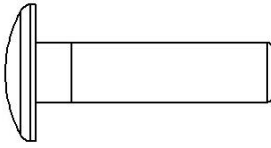
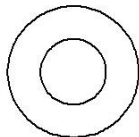
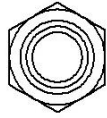
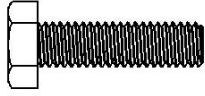
#	TO SCALE	DESCRIPTION	QTY.
1		.25-20 x 1.25 HH	4
2		.25-20 x 1.0 Flanged HH	3
3		.25-20 x .625 Flange HH	14
4		.375-16x.75 Thread Forming	2

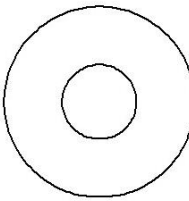
#	TO SCALE	DESCRIPTION	QTY.
5		.312x1 Self Tapping	1
6		14-10x.75 Sheet Metal Screw	4
7		.25 Flat Washer	4
8		.25 Split Lock Washer	4
9		.25-20 Flanged Nyloc Nut	17
10		.25-20 Plus Nut	4
11		.312-18 x 1.25 Carriage Bolt	2
12		.312 FLAT WASHER	2
13		.312-18 nylock nut	2
14		M6 x 25 HH	2
15		M6 Flat Washer	2
16		M6 Split Lock Washer	2
17		.375 x 1.0 Nylon Spacer	4

Step 1 – Assemble Side Wings

- Bolt partition (40640) to side wings (B & C) using a 5/16" x .625" flanged bolt (3) and a 5/16" flanged nyloc nut (9).

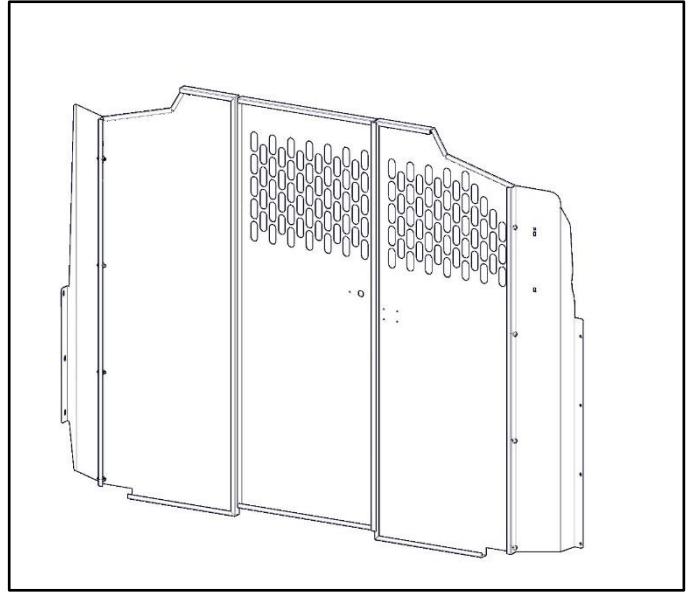
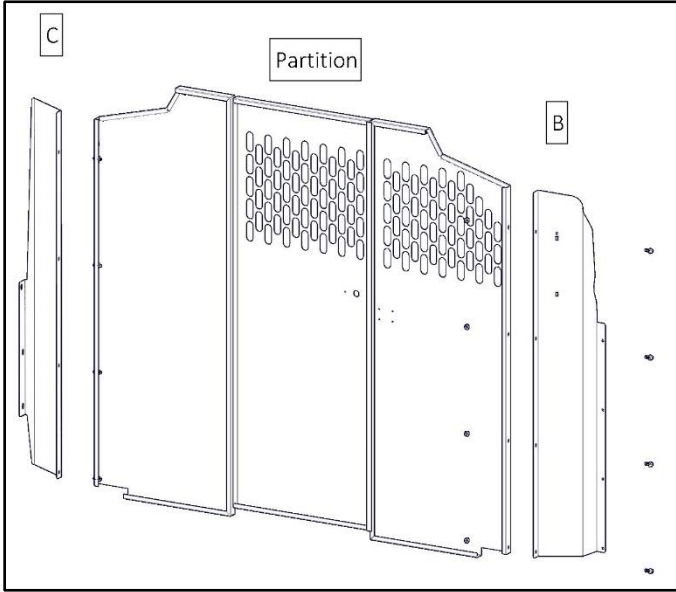
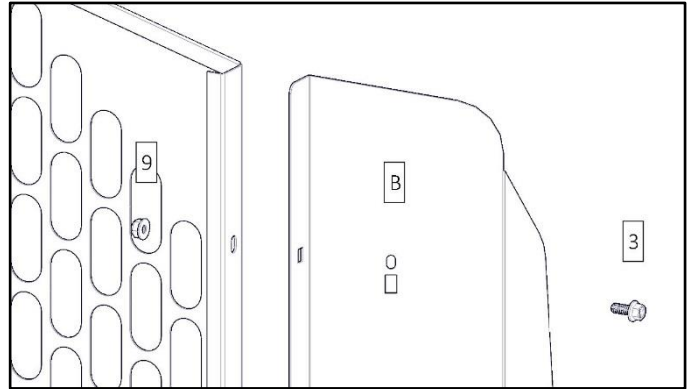

Step 2 – Assemble Top Wings

- Bolt partition to top wing (A) using a 5/16" x .625" flanged bolt (3) and a 5/16" flanged nyloc nut (9).

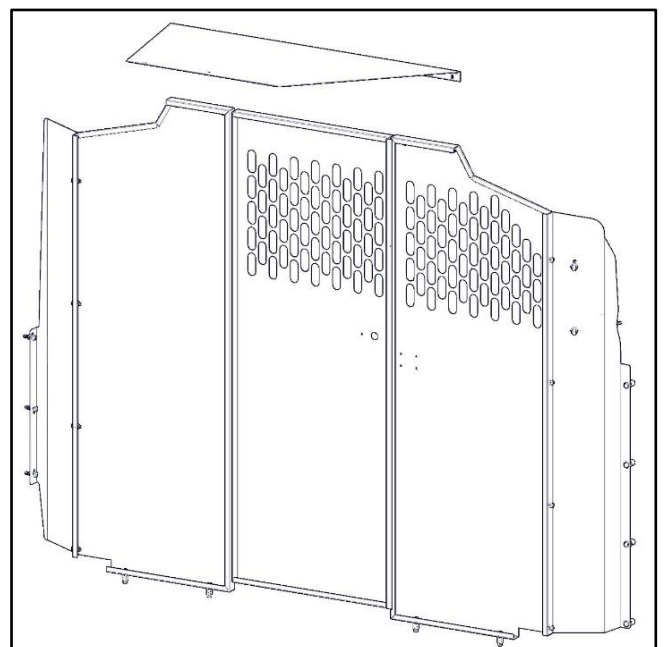
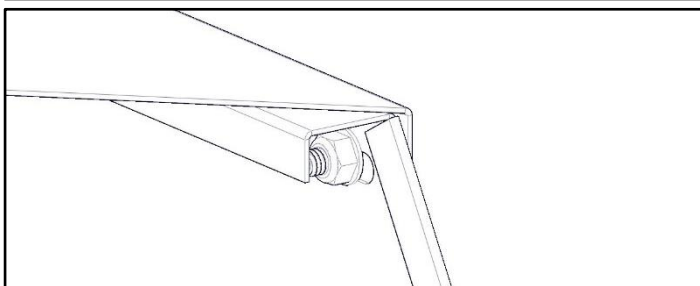
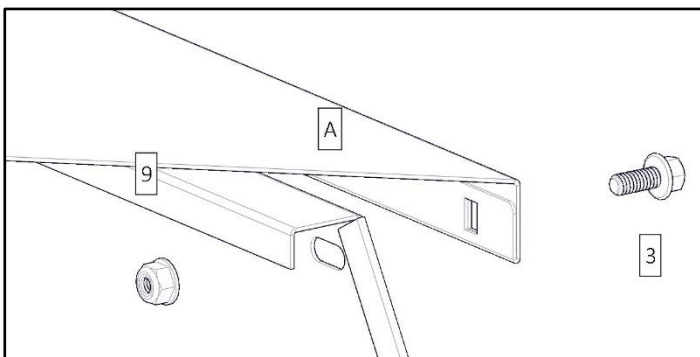

Step 3 – Handle Replacement

- Remove handle from slider doorway as shown below.

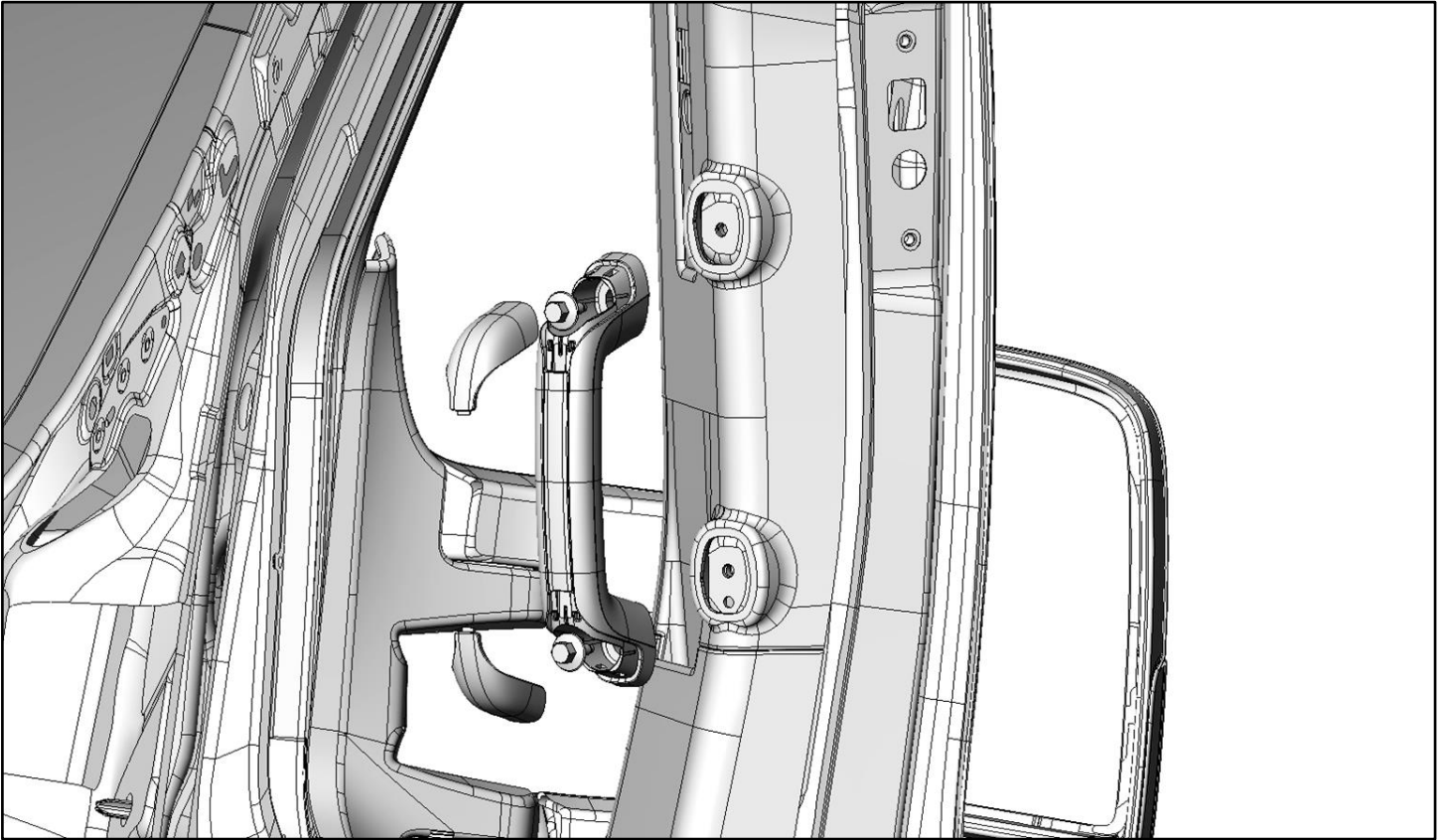

- Install handle mount (D) where handle was previously removed using M6 x 25mm HH (14), M6 lock washer (16) and a M6 split lock washer (15). **SNUG TIGHTEN.**

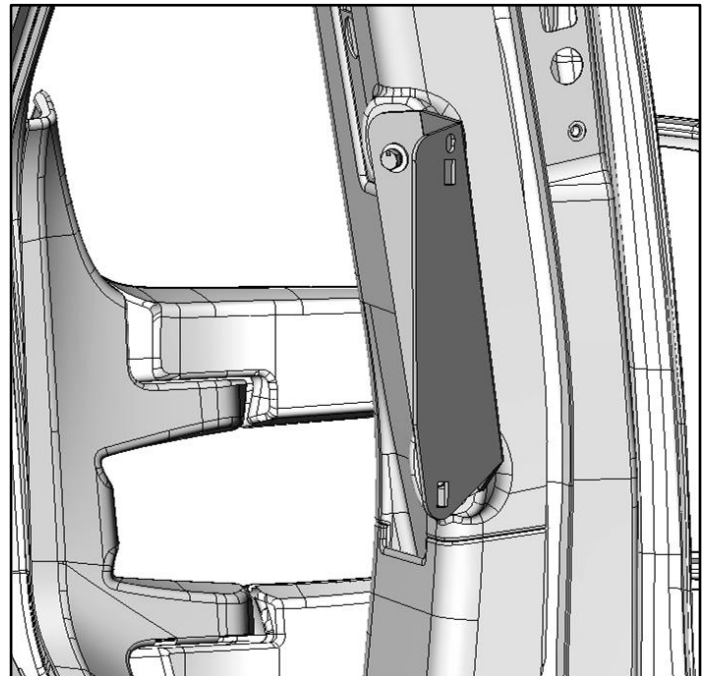
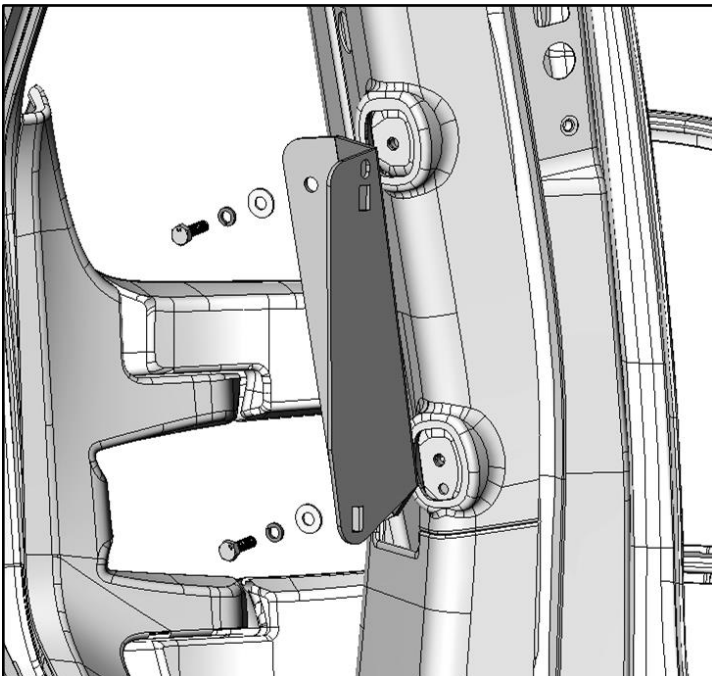

Step 4 – Installation of Plusnut

- Place assembled partition into van with the top wing facing extended to the rear.
- Push the partition firm against the passenger side “B” pillar.
- Align holes in passenger side wing (B) with previously installed handle mount (D).
- On the drivers side, the wing should line up with three existing holes on the side of the van.
- Use a straight edge to ensure the bottom of the partition is straight and square with van.
- Be sure this is the location that the partition is desired.
- Mark all holes and slots along floor.
- Remove partition with wings.
- Determine which two locations on each partition panel to drill into floor.
- Drill through previously marked locations with a 25/64” bit.

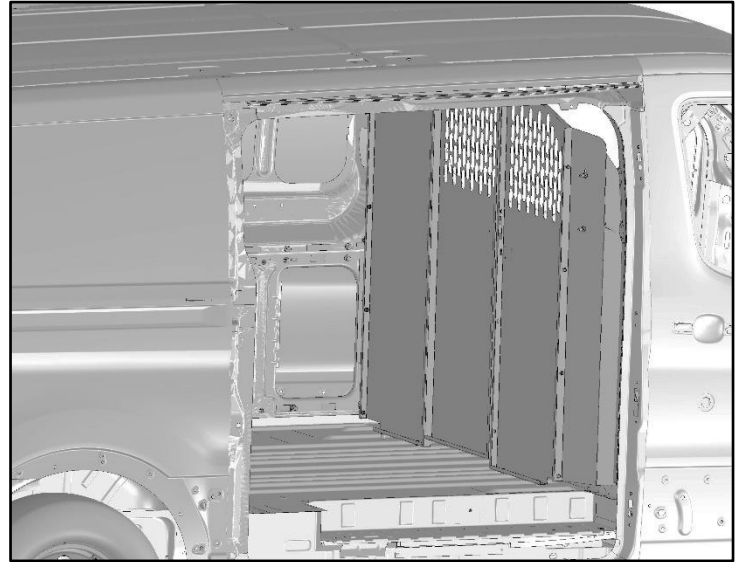

****Use a drill stop to avoid unnecessary damage****

- Install 4 plusnuts along the floor.

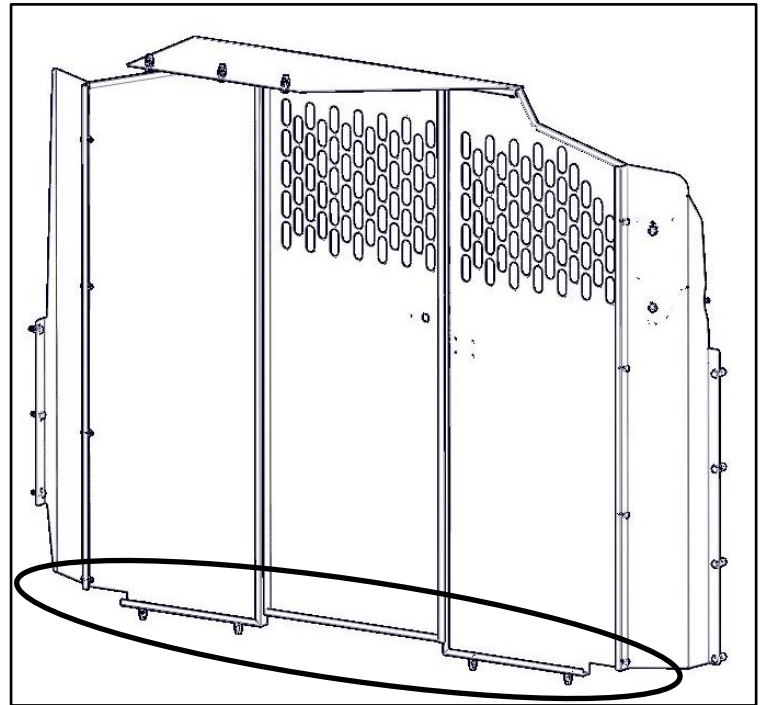

Step 5 – Bolt partition into place

- Place assembled partition with wings back into van. Align with previously installed plus nuts.

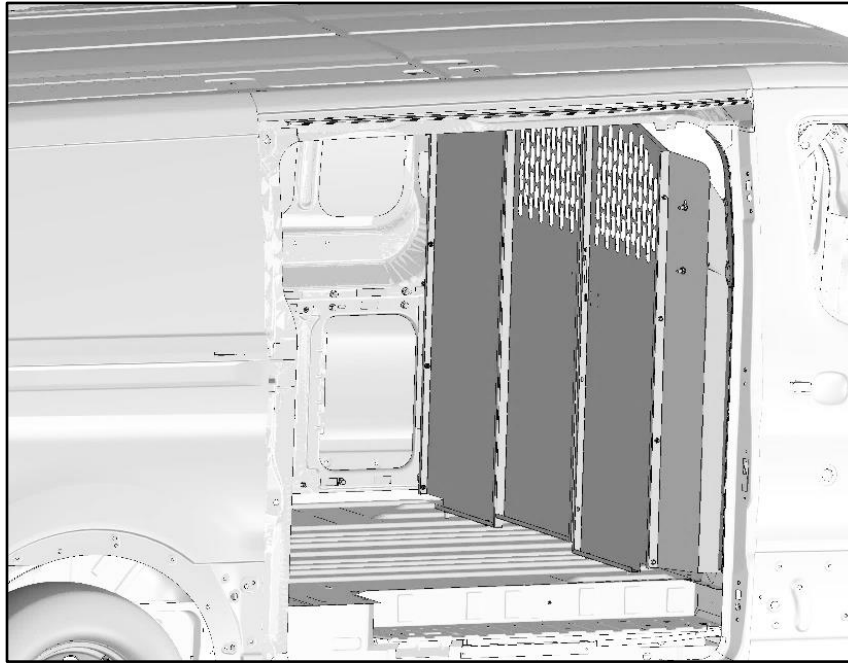

- Along the floor, at each plusnut, bolt through partition panels using 1/4" x 1.25" hex head (1), 1/4" lock washer (8) and a 1/4" flat washer (7). Insert nylon spacer (17) underneath partition if needed. **SNUG TIGHTEN**

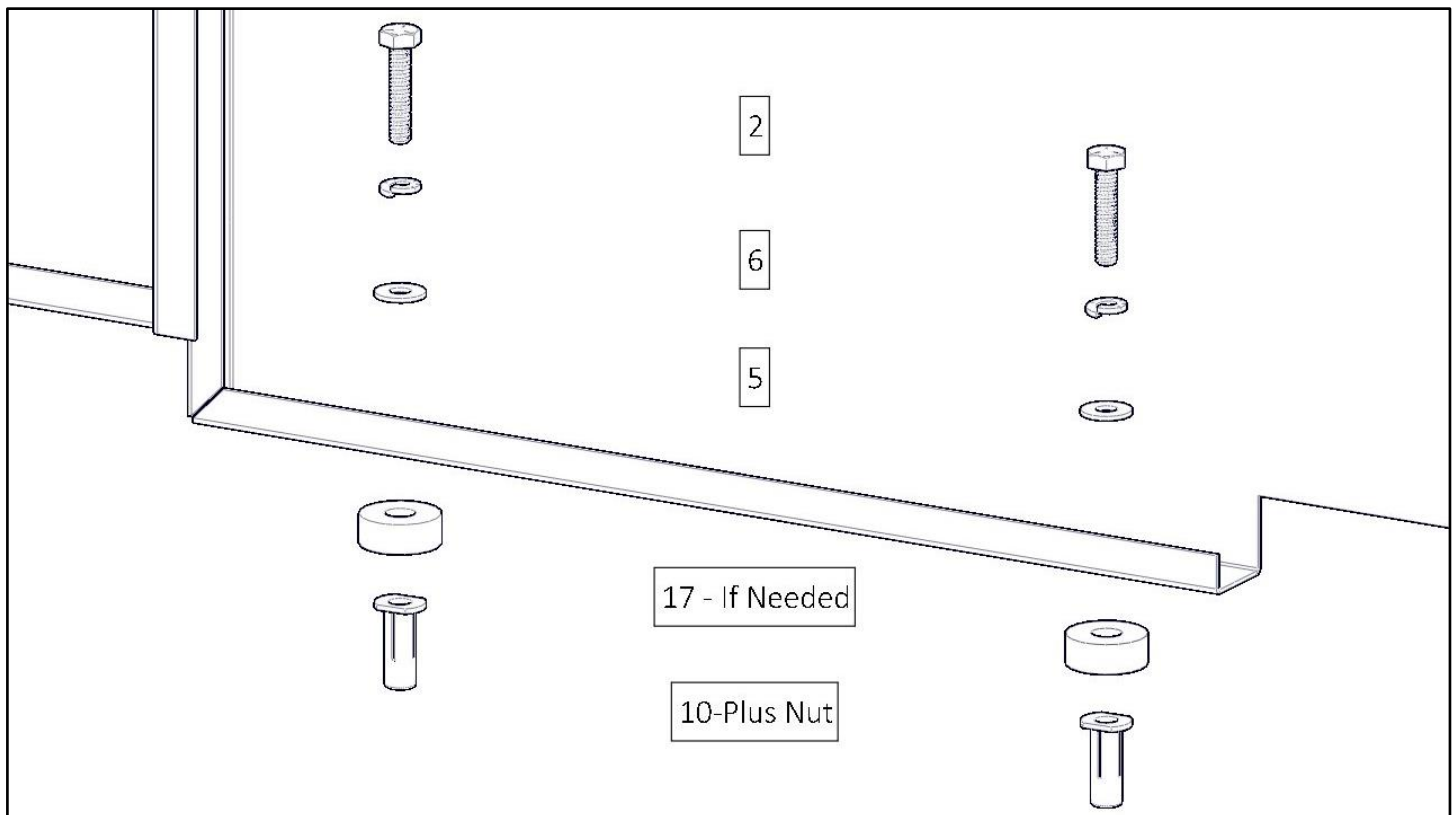

Step 6 – Bolt driver side wing

- On the drivers side of van, the drivers wing (3) should line up with 3 factory holes in the siding of the van.
- Bolt through the wing and the hole in the side of the van using a 1/4" x 1" flanged hex head bolt (2) and a 1/4" flanged nyloc nut (9). **SNUG TIGHTEN**

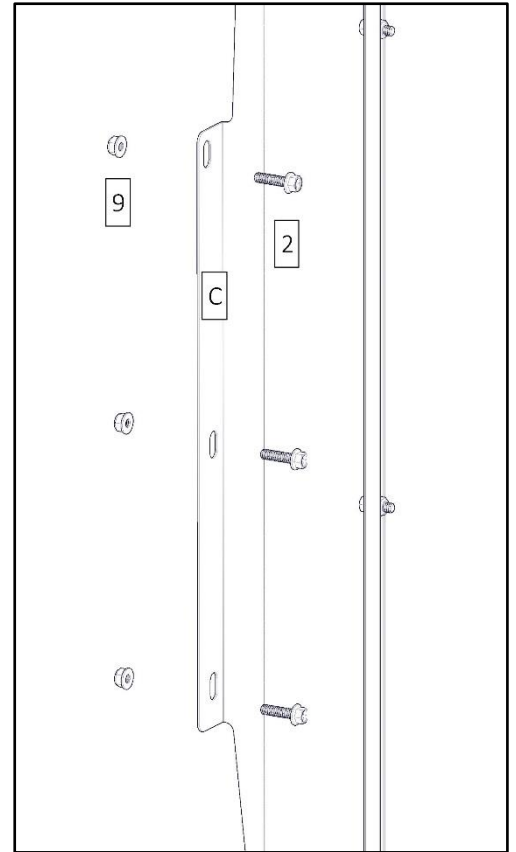
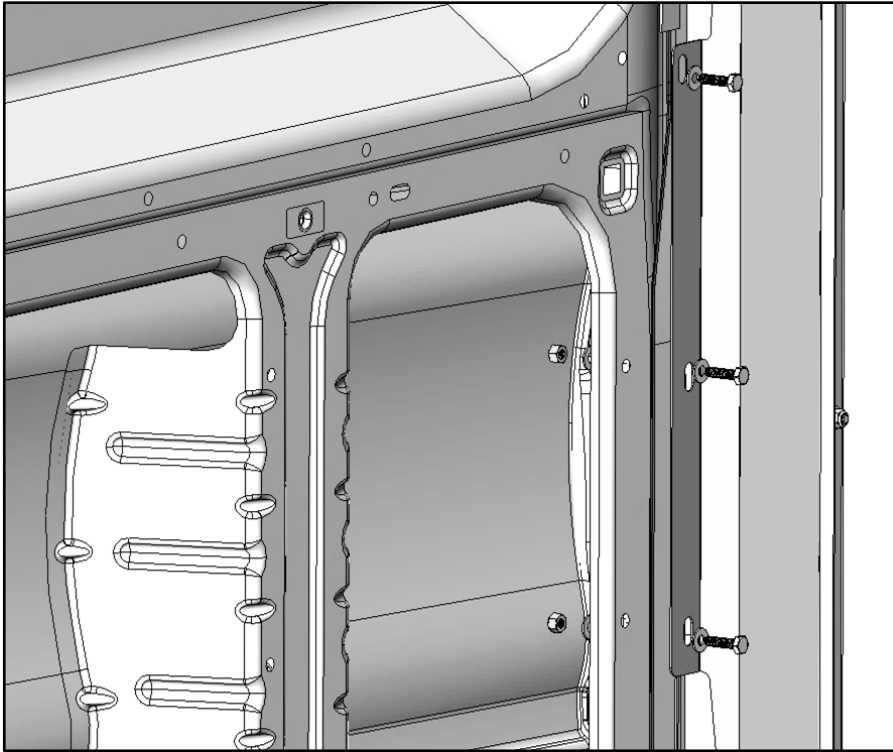

Step 7 – Handle to Handle Bracket

- Bolt previously removed handle from slider door way through the passenger side wing (B) to handle mount (D) installed in Step 3.
- From the backside, place two 5/16" x 1.25" carriage bolts (11) through the rectangular slots in the handle mount (D), through the wing (B), through factory handle, through 5/16" flat washers (12) and into 5/16" nyloc nuts (13). **SNUG TIGHTEN.**

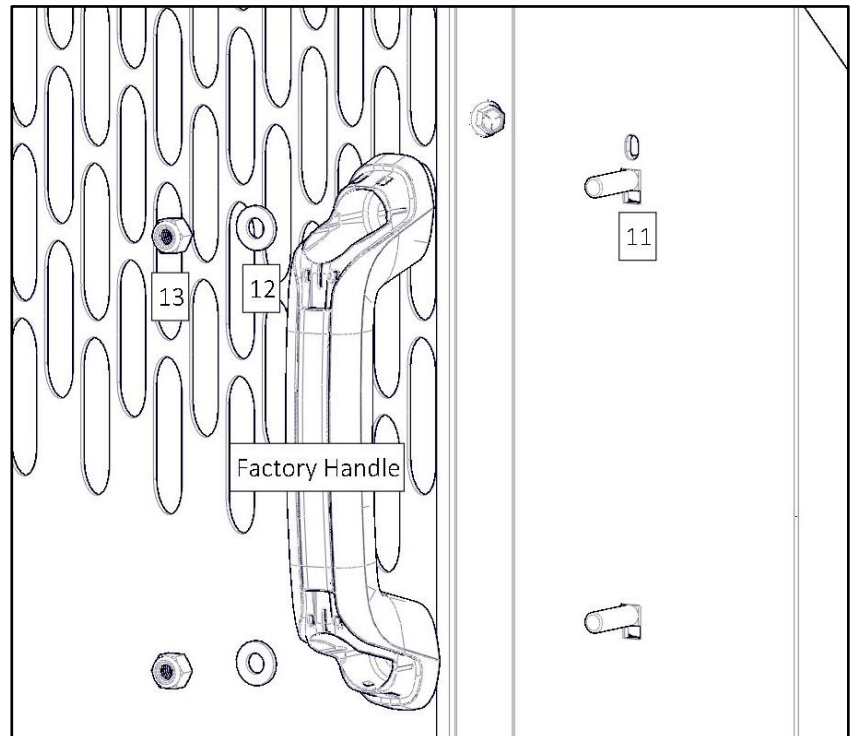

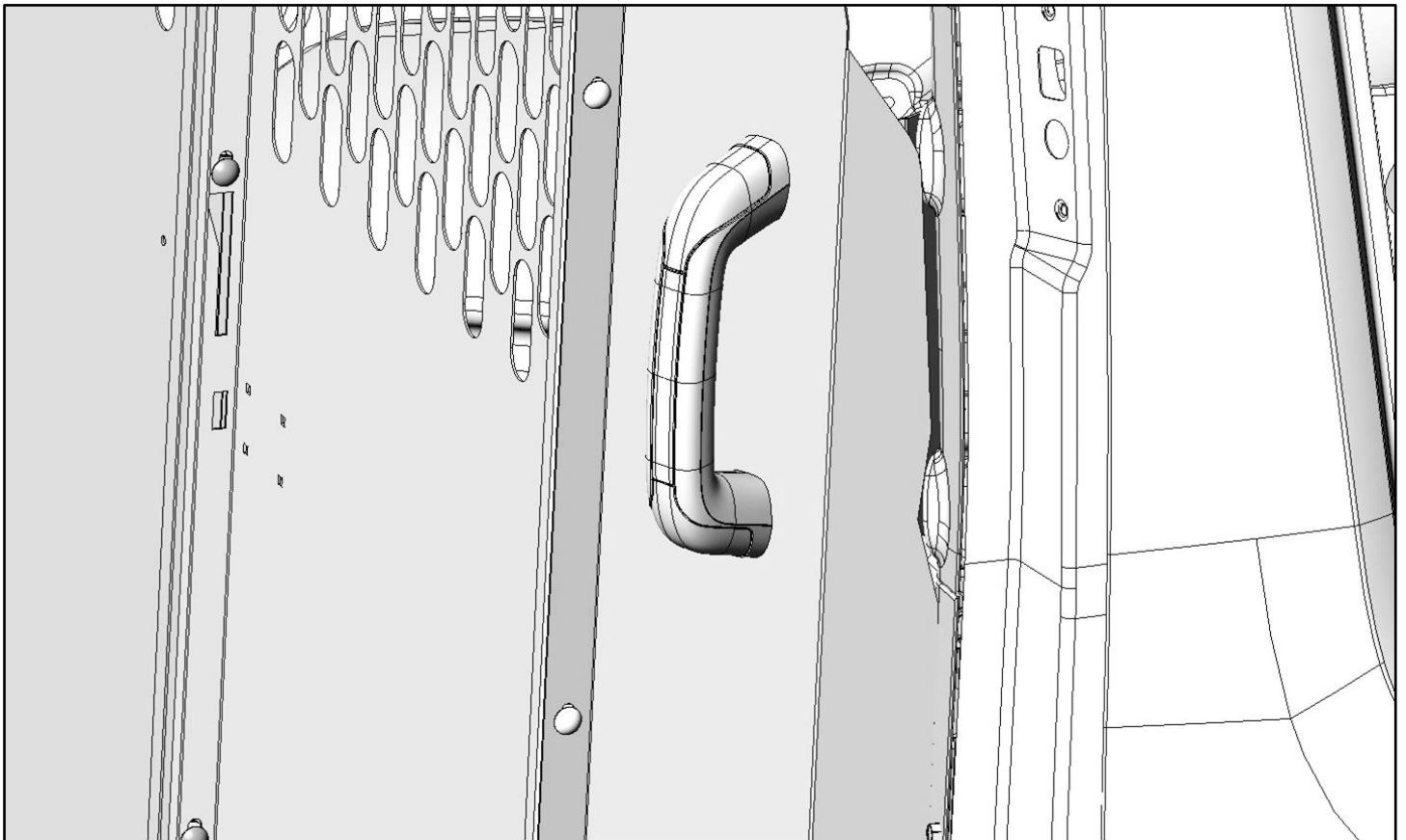
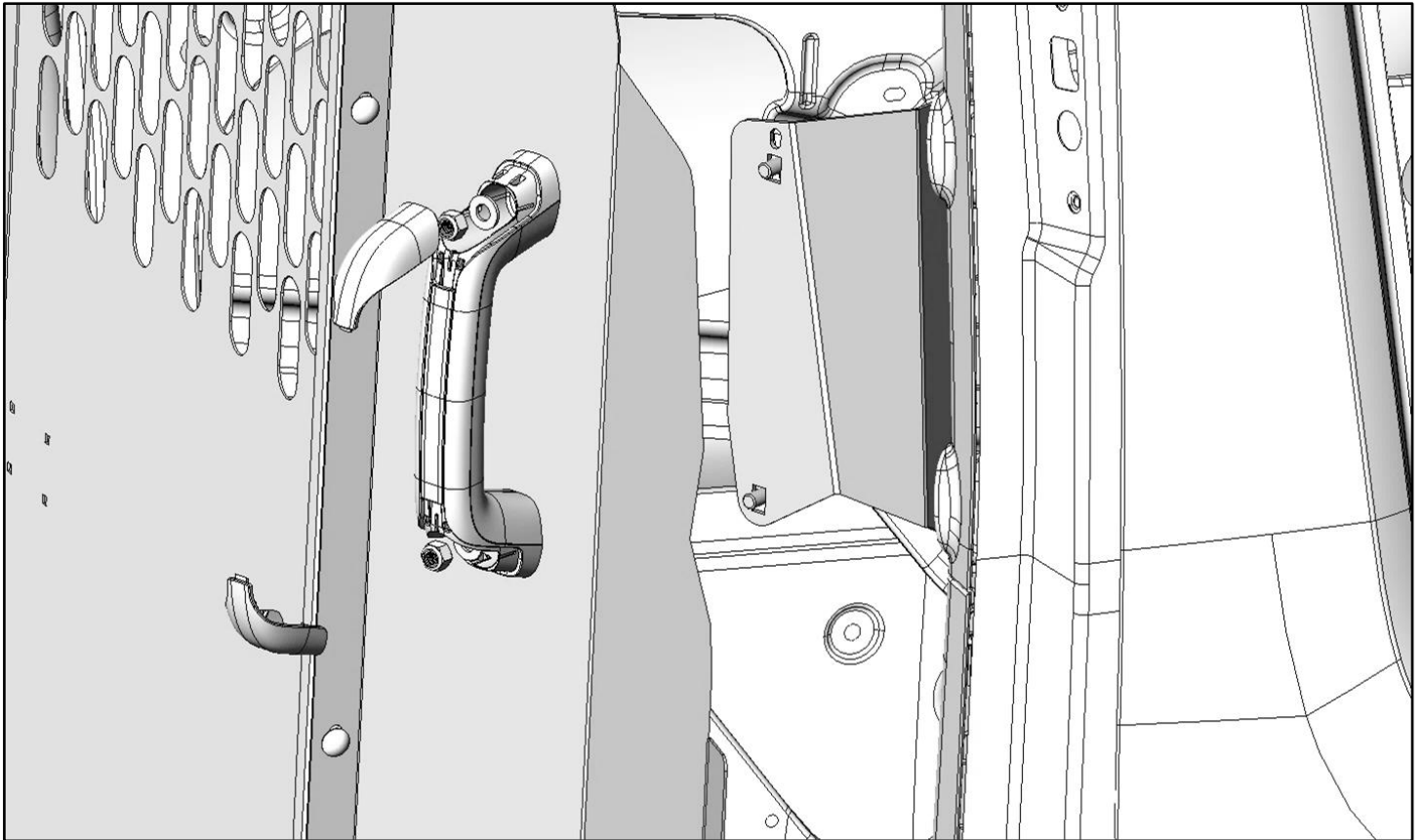

Step 8 – Passenger wing to “B” Pillar

- Screw passenger side wing into “B” pillar using four #14 x .75” sheet metal screws (6).
Prior to installing, ensure it is safe to screw into “B” pillar.

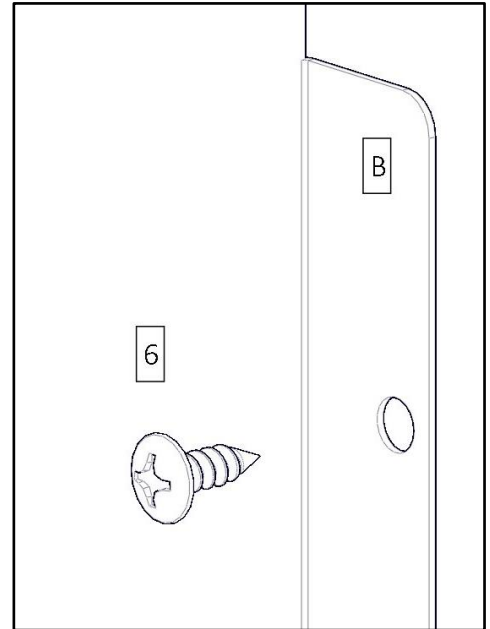
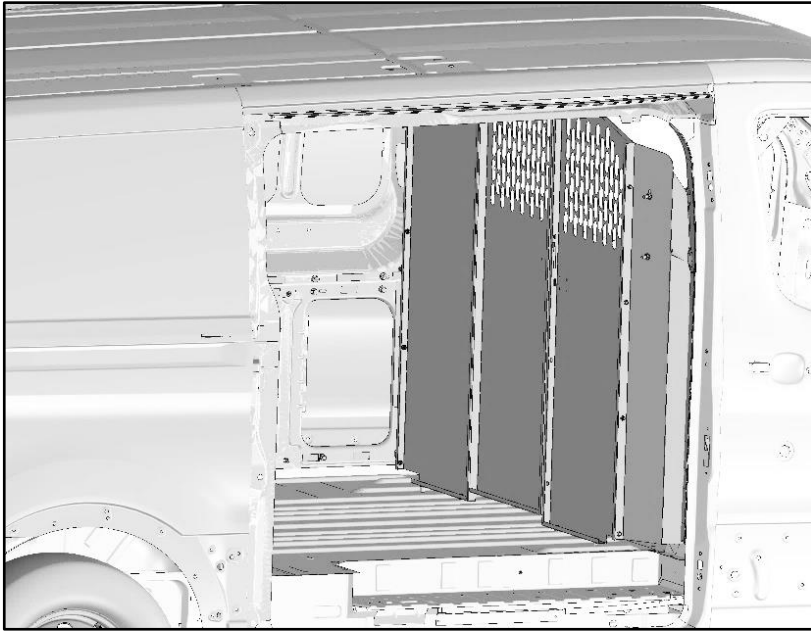

Step 9 – Top wing

- Screw top wing into cross member along the roof using two .375 x .75 thread forming screws (4) and one .312 x 1” self tapping screw (5).

Prior to inserting screws, ensure it is safe to screw into roof.

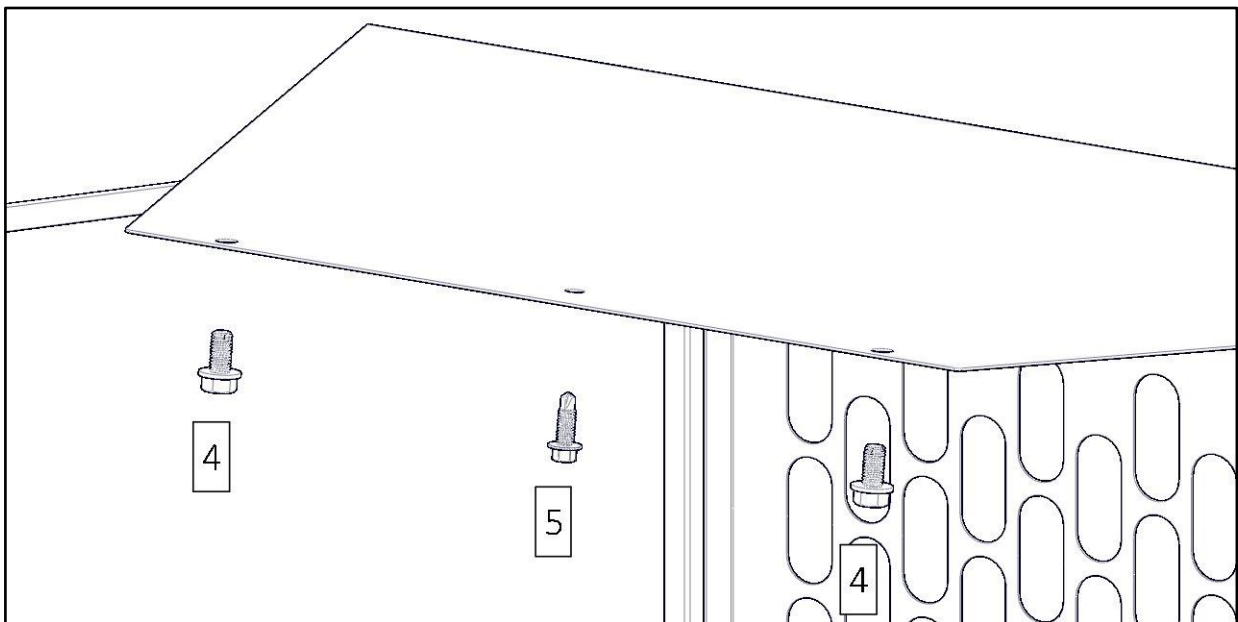

GO BACK AND TIGHTEN ALL BOLTS.
YOUR INSTALLATION IS NOW COMPLETE